

Allestitenti Pompe Moro
Via Pontebbana 16
33080 Fiume Veneto (PN)
Tel.0434/951211
Telex 450276
Telefax 0434/957786

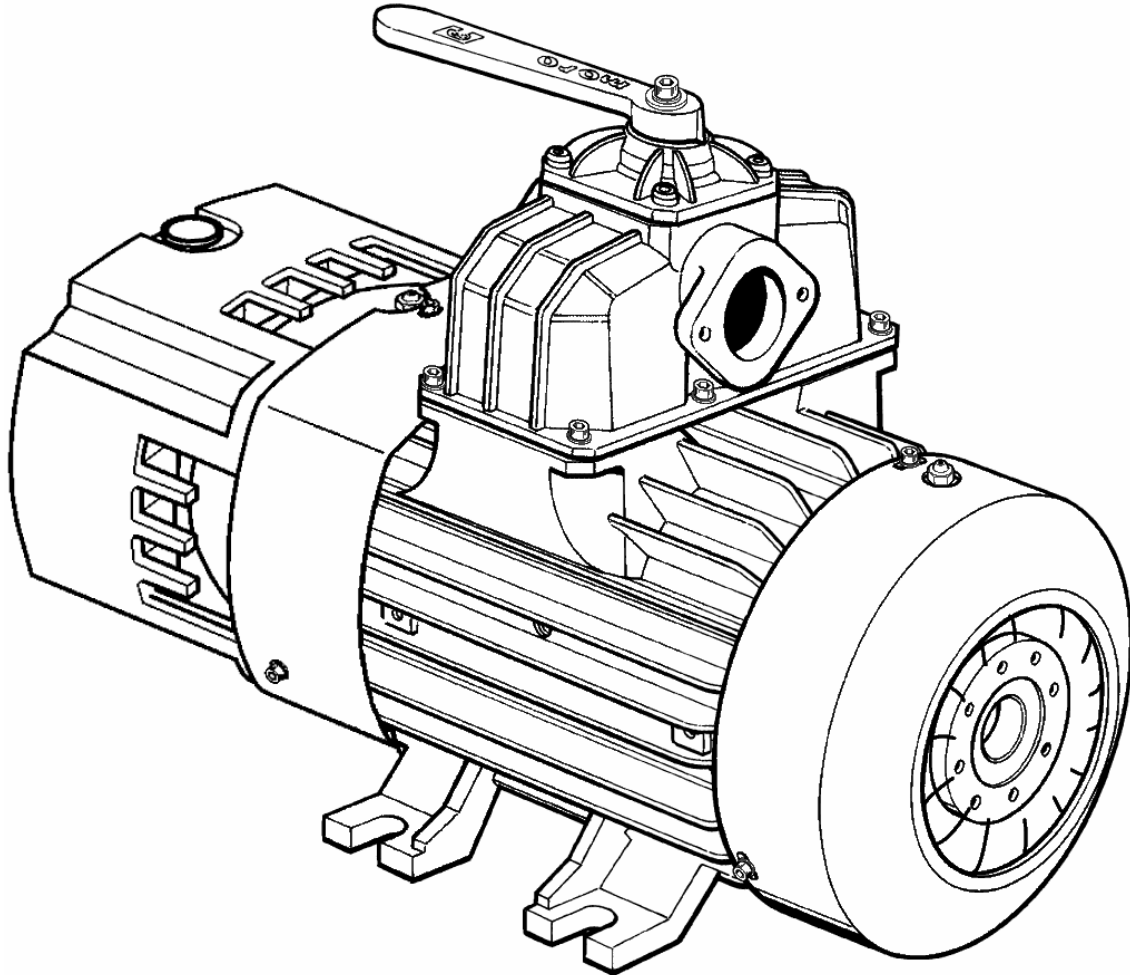

- PARTI DI RICAMBIO -
- PIECES DE RECHARGE -
- ERSATZTEILLISTE -
- SPARE PARTS -

DECOMPRESSORE TURBO PM80 CON VENTOLE
POMPE A VIDE TURBO PM80 AVEC VENTILATEURS
VAKUUMPUMPE TURBO PM80 MIT LÜFTERRÄDERN
TURBO PM80 VACUUM PUMP WITH FANS

1008128-9 SX
1008134-1 DX

DECOMPRESSORE TURBO PM80
POMPE A VIDE TURBO PM80
VAKUUMPUMPE TURBO PM80
TURBO PM80 VACUUM PUMP

Allestimenti Pompe Moro
Via Pontebbana 16
33080 Fiume Veneto (PN)
Tel.0434/951211
Telex 450276
Telefax 0434/957786



Pos.	Q.tà	Codice	Denominazione	Nomenclature	Bezeichnung	Denomination
			Gruppo anteriore presa diretta	Groupe antérieur prise directe	Unmittelbarer Gang Frontgruppe	Front group direct jack
1						
2						
3	1	6445-0000-0	Filtro olio	Filtre à huile	Ílfilter	Oil filter
4	3	6575-0054-2	Lamella	Palette	Lamelle	Vane
5	1	6624-0051-0	Corpo	Corps	Gehäuse	Housing
6						
7	2	92-1003-522	Anello OR	Anneau OR	O-Ring	O-Ring
8	1	92-4019-025	Raccordo a gomito	Raccord coudé	Anschluß	Fitting
9	4	92-4061-050	Raccordo a gomito	Raccord coudé	Anschluß	Fitting
10	2	92-5070-000	Tappo conico	Bouchon conique	Konischer Stpsel	Conical plug
11	1	1008163-5	Pompa olio dx	Pompe à huile dx	Oelpumpe dx	Oil Pump dx
11	1	1008169-9	Pompa olio sx	Pompe à huile sx	Oelpumpe sx	Oil Pump sx
12	2	93-1004-004	Cuscinetto	Roulement	Lager	Ball bearing
13	11	96-1013-002	Vite	Vis	Schraube	Screw
14	17	96-1013-003	Vite	Vis	Schraube	Screw
15	2	96-1073-002	Vite	Vis	Schraube	Screw
16	1	96-3000-018	Linguetta	Clavette	Feder	Key
17	2	96-3005-004	Anello di compensazione	Anneau	Ring	Ring
18	28	96-4001-002	Rondella	Rondelle	Scheibe	Washer
19	1	6761-0002-0	Tubo olio dx-sx	Tuyau	Schlauch	Tubing
20	1	6024-0004-0	Leva	Levier	Hebel	Handle
21	1	6264-0028-0	Deviatore	Déviateur	Umschaltvorrichtung	Change-over Device
22	1	6264-0063-0	Collettore	Collecteur	Pumpenoberteil	Manifold
23	1	6633-0097-0	Coperchio	Couvercle	Deckel	Cover
24	1	6805-0261-0	Guarnizione	Joint	Dichtung	Gasket
25	1	6806-0016-0	Guarnizione	Joint	Dichtung	Gasket
26	1	96-1075-004	Vite	Vis	Schraube	Screw
27	1	6900-0034-2	Molla	Ressort	Feder	Spring
28	1	6925-0002-0	Valvola	Soupape	Ventil	Valve
29	1	92-1027-065	Anello tenuta	Anneau détanchéité	Simmerring	Ring seal
30	1	96-4005-005	Rondella	Rondelle	Scheibe	Washer
31	1	6400-0052-0	Coperchio	Couvercle	Deckel	Cover
32	3	6120-0447-0	Supporto	Support	Halterung	Support
33	1	6400-0021-0	Convogliatore anteriore	Guide	Führung	Conveyor
34	1	6450-0063-0	Carter	Carter	Gehäuse	Carter
35	1	6110-0123-0	Mozzo posteriore	Moyeu	Nabe	Hub
36	1	6560-0020-0	Mozzo	Moyeu	Nabe	Hub
37	1	6730-0200-0	Tubo di lubrificazione	Tuyau de graissage	Einschmierungsrohr	Lubrication pipe
38	1	6830-0010-1	Rondella	Rondelle	Scheibe	Washer
39	2	92-1002-004	Anello tenuta	Anneau détanchéité	Simmerring	Ring seal
40	4	92-1027-058	Anello tenuta	Anneau détanchéité	Simmerring	Ring seal
41	2	92-9080-000	Ventola	Hélice	Lüfterrad	Fan
42	1	93-1000-002	Cuscinetto	Roulement	Lager	Ball bearing
43	1	96-1021-001	Vite	Vis	Schraube	Screw
44	6	96-1075-001	Vite	Vis	Schraube	Screw
45	1	96-4001-003	Rosetta elastica	Rondelle élastique	Federscheibe	Elastic washer
46	6	96-4007-001	Rondella piana	Rondelle	Scheibe	Washer
47	2	96-5001-001	Ingrassatore	Nipple de graissage	Schmiernippel	Grease nipple
48	4	96-1071-110	Vite	Vis	Schraube	Screw
49	1	6104-0062-0	Flangia	Flasque	Flansch	Flange
50	2	6634-0031-0	Coperchio	Couvercle	Deckel	Cover
51	1	6110-0098-2	Mozzo anteriore	Moyeu	Nabe	Hub
52	1	6534-0079-1	Rotore	Rotor	Läufer	Rotor
53	8	96-1075-103	Vite	Vis	Schraube	Screw
54	4	96-4027-002	Spina cilindrica	Goujon	Stift	Pin
55	1	6613-0003-0	Serbatoio olio	Reserved huile	Ölbehälter	Oil tank
56	1	92-1003-517	Anello O.R. Viton	Anneau torique	Rundschnurring	O-ring
57	1	92-1003-516	Anello O.R. Viton	Anneau torique	Rundschnurring	O-ring
58	1	6633-0098-1	Coperchio serbatoio olio	Couvercle	Deckel	Cover
59						
60	1	6220-0497-0	Boccola	Bague	Lager	Bushing
61	1	6104-0163-0	Flangia	Flasque	Flansch	Flange
62	1	96-3001-030	Anello "Seeger"	Anneau "Seeger"	Ring "Seeger"	Ring "Seeger"
63	2	92-4063-101	Raccordo	Raccord	Anschluß	Pipe fitting
64	1	6845-0000-0	Tappo	Bouchon	Deckel	Plug
65	2	96-5022-002	Spia livello	Voyant de niveau	Standanzeiger	Level light
66	1	96-5023-003	Tappo	Bouchon	Deckel	Plug
67	6	96-1075-003	Vite	Vis	Schraube	Screw

1008128-9 SX
1008134-1 DX

DECOMPRESSORE TURBO PM80
POMPE A VIDE TURBO PM80
VAKUUMPUMPE TURBO PM80
TURBO PM80 VACUUM PUMP

Allestitimenti Pompe Moro
Via Pontebbana 16
33080 Fiume Veneto (PN)
Tel.0434/951211
Telex 450276
Telefax 0434/957786



Pos.	Q.tà	Codice	Denominazione	Nomenclature	Bezeichnung	Denomination
68	4	96-1078-110	Vite	Vis	Schraube	Screw
69	1	6730-0548-0	Tubo per ingrassatore	Tuyau de graissage	Einschmierungsrohr	Lubrication pipe
70						
71	2	1008170-6	Guarnizione	Joint	Dichtung	Gasket
72	1	1008162-6	Perno	Pivot	Zapfen	Pin
73	2	1008227-9	Raccordo 90° orientabile	Raccord	Anschluß	Fitting
74	0,54	92-4054-196	Tubo flessibile	Goujon	Stift	Dowel
75	1	1008360-6	Tubo olio sx	Tuyau	Schlauch	Tube
75	1	1008378-6	Tubo olio sx	Tuyau	Schlauch	Tube
76	1	1008376-8	Tubo olio sx	Tuyau	Schlauch	Tube
76	1	1008379-5	Tubo olio dx	Tuyau	Schlauch	Tube
77	4	1008454-3	Tappo	Bouchon	Deckel	Plug
		1008649-9	Serie guarnizioni TURBO PM80	Jeu de joints TURBO PM80	Dichtungssatz TURBO PM80	TURBO PM80 kit of gaskets

1008128-9 SX
1008134-1 DX

DECOMPRESSORE TURBO PM80
POMPE A VIDE TURBO PM80
VAKUUMPUMPE TURBO PM80
TURBO PM80 VACUUM PUMP

Allestitenti Pompe Moro
Via Pontebbana 16
33080 Fiume Veneto (PN)
Tel.0434/951211
Telex 450276
Telefax 0434/957786

